

PUMP TECHNOLOGY
FOR
DISASTER RELIEF



Photo: Feuerwehr Oberndorf



Photo: THW-Senftenberg

YOU CAN RELY ON THEM: QUALITY DOWN TO THE LAST DETAIL

B

Market leader for elastomer-coated rotary lobe pumps and experts in mobile pumps. We are represented in more than 65 countries and remain on course for growth. Not only are we a global player. But also an independent, family-owned and second generation managed company.

"Constantly making things better" has been our guiding principle right from the start. This is evident by the quality, durability and ease of maintenance of our products. Not only has it shaped our company history since 1975 with continuous new developments and innovations, it also is expressed in the honest and reliable partnership with customers, suppliers and staff.

Our mobile pumps for disaster relief are customized to the specific demand. Whether as a high-performance pump on a truck trailer, ATEX-compliant hand cart pump or PTO shaft pump – our experienced experts know the requirements, recommend suitable products or develop individual solutions for you. Highest quality "Made in Germany".

BÖRGER®

EXCELLENCE – MADE TO LAST

Börger products are designed for trouble free, continuous operation. We want you to be able to work as effectively as possible. This is the reason why we only offer powerful and durable rotary lobe pumps with unbeatable ease of maintenance features.



MADE FOR PRACTICAL USE

MOBILE PUMP TECHNOLOGY FROM BÖRGER

Fast, uncomplicated and effective action is part of your everyday working life. You need reliable technology for this purpose. This reliability is offered by our products which have been used by fire departments, the Technisches Hilfwerk (THW), dike associations, private industries and numerous local authorities for years.

Whether in case of flooding, overloaded sewage systems, flooded roads or for fire extinguishing – high-performance mobile pumps are mandatory in these emergency situations.

FIRE DEPARTMENT

THW

**LOCAL AUTHORITIES,
DIKE ASSOCIATIONS,
GENERAL INDUSTRY,**



+Photo: thwiki.com Thiemo Schuff

+Photo: THW Bad Segeberg

+Photo: THW

ÖLWEHRGERÄT
DER 791

COMPACT. POWERFUL. RELIABLE. THE IDEAL MOBILE PUMP

The compact, low-on-space design, unproblematic pumping in slurrp operation and the possibility to drive a Börger rotary lobe pump by means of different drive options are reasons why our pump is the ideal mobile pump.

Börger mobile pumps are designed and built in line with your needs! Everything from a single source – Börger designs and produces the base frame, the pump technology and the control technology themselves.



ROTARY LOBE PUMPS

Börger is a specialist in rotary lobe pumps. We offer solids-resistant rotary lobe pumps with flow rates of 1 – 24,000 l/min and a large selection of equipment and additional parts.

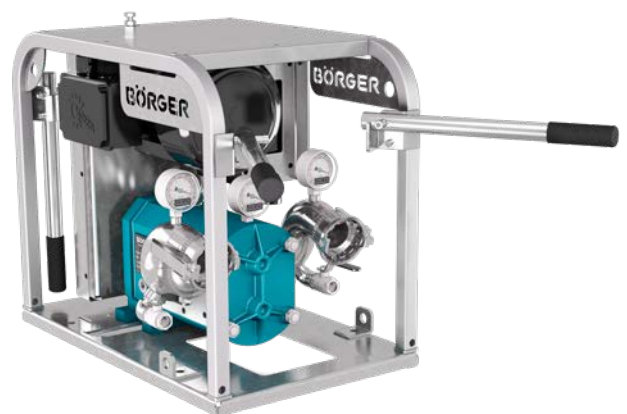

PORTABLE HAND CART PUMPS

The portable rotary lobe pump can be either driven by an electric or a combustion motor and can be manufactured in ATEX- or API 676-compliant design depending on the application. The maximum flow rate is 500 l/min.



HIGH-PERFORMANCE PUMPS ON TRUCK TRAILERS

Our high-performance pumps are installed on truck trailers together with the drive. The BLUEline XL rotary lobe pump with a flow rate of up to 24,000 l/min is the most powerful rotary lobe pump in the world.

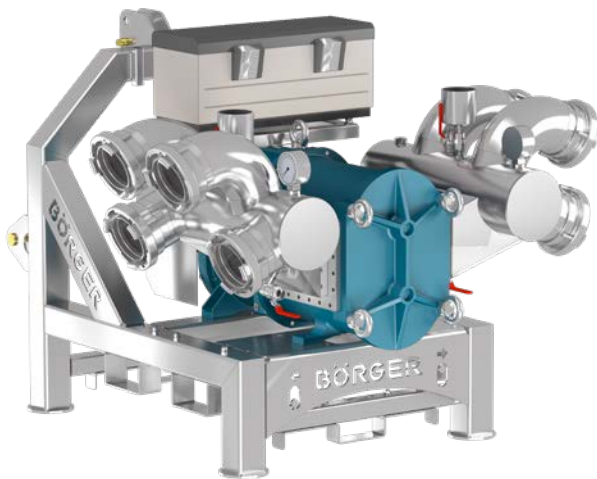

EMERGENCY PUMPS

The PTO shaft pumps are installed on a base frame with standardized three-point mounting and dispense with an integrated drive. The mobile pumps can be transported even to rough terrain by a tractor or Unimog and driven by the auxiliary drive of the vehicles. The pumps convey up to 15,000 l/min.



MOBILE PUMPS ON CAR TRAILERS

Our rotary lobe pumps with a maximum flow rate of up to 15,000 l/min can be installed on a car trailer.

ROTARY LOBE PUMPS BY BÖRGER

SOPHISTICATED TECHNOLOGY

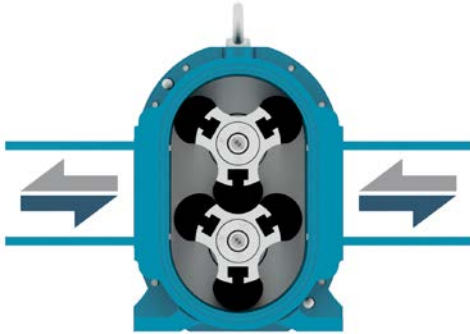

Börger rotary lobe pumps have been used in disaster relief for more than 30 years. The solids handling pumps are powerful, reliable and efficient. Börger pumps convey dirty, sludgy and abrasive media without problems.

OPERATING PRINCIPLE

Börger rotary lobe pumps are self-priming, valveless, positive displacement pumps. The synchronized rotation of the rotor pair creates a vacuum on the priming side of the pump. This vacuum draws the liquid into the pump chamber. The medium is pumped into the pressure area due to the rotation of the rotors. If the direction of rotation is changed, the flow is reversed.

CONSTRUCTION

- 1 The quick-release cover**
Access to all wetted parts by simply loosening four ring nuts.
- 2 The rotors**
Large selection of high-quality rotors for almost pulsation-free pumping of the medium.
- 3 The casing protection**
The casing liners and casing protection plates protect the pump casing from wear and can be replaced in a matter of minutes. For conveying pure, non-abrasive media, the Nova series AN, PN and QN are also available as a "clean" version without protection plates and liners.
- 4 The intermediate chamber and shaft seal**
The large-volume quench chamber is oil-filled and ensures the highest degree of safety. The ideal mechanical seal is selected depending on the medium.
- 5 The carrier and timing gear**
The high-quality and maintenance-free carrier and timing gear guarantees a smooth and even operation of the rotors. The result is a long service life of the pump.



BLUEline Legend



BLUELINE AT A GLANCE

+ 25 pump sizes with flow rates of
1 – 24,000 l/min

+ Self-priming, pumping in slurp operation

+ Resistant to solids

+ Constant flow rate even with increasing
pressure

+ Compact, space-saving design

+ Cantilevered carrier design

+ Reversible

Series	Flow rate in l/min		Max. pressure in bar	Max. ball passage in mm
	Min.	Max.		
BLUEline Nova AN	0.5	580	10	30
ONIXline BJ	0.9	1,120	16	30
BLUEline Nova PN	1.0	1,280	12	42
BLUEline Nova QN	2.3	1,800	8	48
BLUEline Legend PL	1.8	1,890	8	40
ONIXline BL	1.9	2,240	16	37,5
BLUEline Legend CL	3.9	3,120	8	50
BLUEline Legend FL	5.7	6,840	12	75
BLUEline Legend EL	10.3	18,540	10	80
BLUEline Legend XL	17.6	23,990	10	95

VARIABLE FLOW RATE

One device – many possibilities: whether for pumping dry cellars or for conveying large quantities of water, a Börger rotary lobe pump is the right choice for you. The flow rate can be adapted to the specific pumping task via the flexible speed of the pump. The high efficiency is maintained at every speed.

e.g. **BLUEline FL 1036**

Speed	Flow rate
100 rpm >	1,140 l/min
600 rpm >	6,840 l/min



UNBEATABLE EASE OF MAINTENANCE THANKS TO MIP® (MAINTENANCE IN PLACE)

Börger products are designed for trouble free, continuous operation and incorporate unbeatable ease of maintenance features. All components are extremely resilient and durable. Instead of expensive maintenance contracts, Börger offers MIP® (Maintenance in Place). Control maintenance and repair procedures yourself. Product wetted parts can be replaced at the installation site without the need to remove piping and the drive system – quickly and easily.



EVERYTHING FROM A SINGLE SOURCE.

UNLIMITED INDIVIDUALITY

Börger offers ready-to-connect solutions. Our pump units are supplied from a single source. Börger designs and produces the base frame, the pump technology and the control technology themselves – in line with your requirements with perfectly matched components.

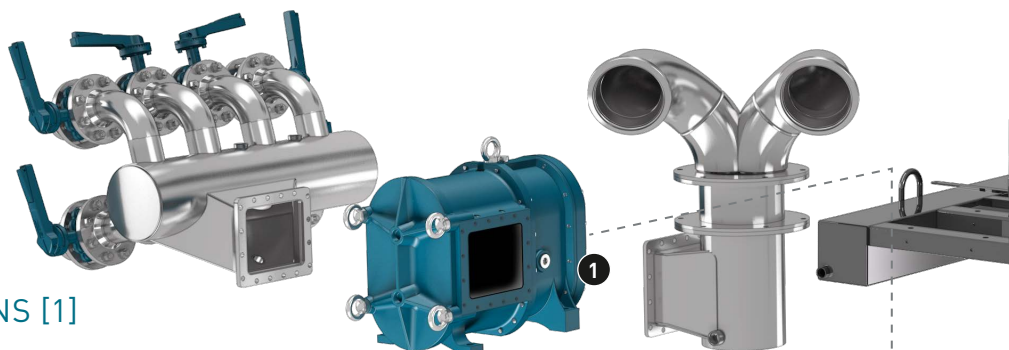

PUMP AND HOSE CONNECTIONS [1]

With the wide spectrum of 25 pump sizes (flow rates of 1 – 24,000 l/min), a large selection of equipment and additional parts, we are able to build rotary lobe pumps which are perfectly suited to every single application. The number of suction and pressure connections is freely selectable.



DESIGN COMPLIANT WITH GUIDELINES

All Börger pump units can be manufactured according to the European ATEX guidelines (2014/34/EU) intended for use in potentially explosive atmospheres. In addition, an API 676-compliant design, a design according to the FDA regulations or a technically tight pump design according to the German TA Luft requirements are possible.

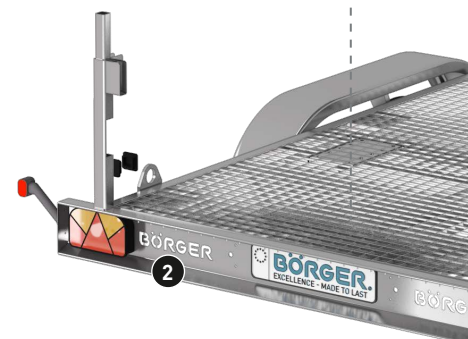

CHASSIS [2]

The chassis for mobile pumps is manufactured by our metal construction department exactly in line with our customers' wishes and requirements. Whether portable base frame with casters, base frame with standardized three-point mounting or trailer chassis – we are able to build whatever you require. Installation on a roll-off container or a lowering frame is also possible. Of course, all trailers are approved by the TÜV before delivery.

ROOF CONSTRUCTION [3]

Our mobile units on car or truck trailers are equipped with different roof constructions. Whether a tarp / roof bow-construction, aluminum roof or noise enclosure of the entire unit – we make everything possible.

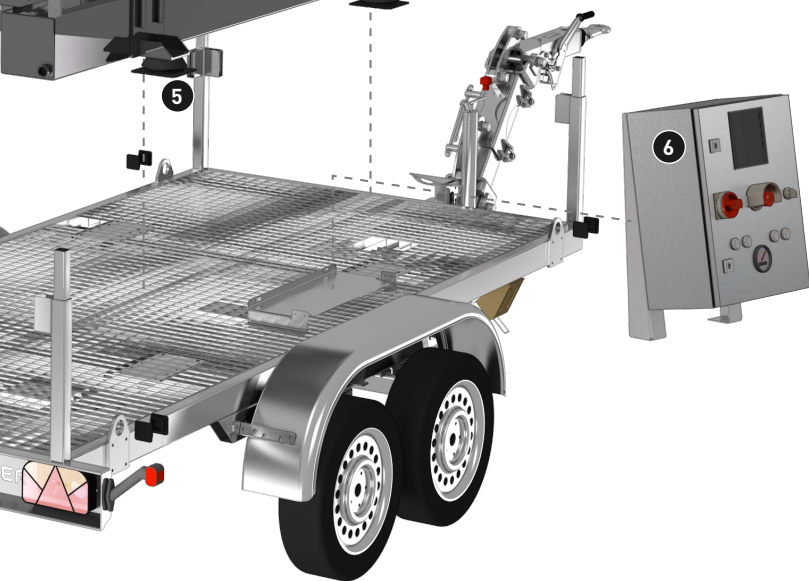
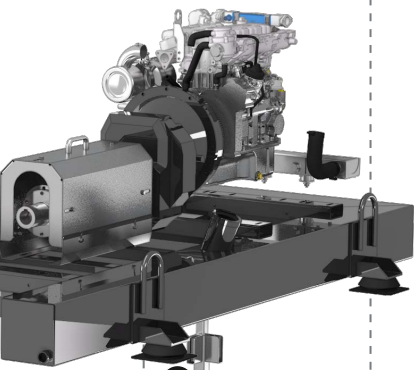
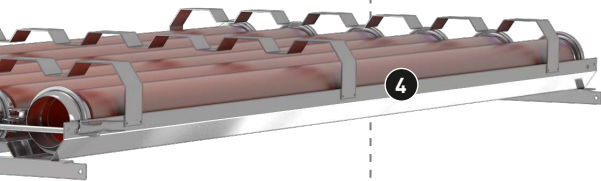

COMPLETE SOLUTIONS AT A GLANCE

- + Customized
- + Perfectly matched components
- + "Everything from a single source" – designed and built by Börger
- + Ready-to-connect complete units
- + ATEX-, TA-Luft-, or API 676-compliant design

SPECIAL ACCESSORIES [4]

During manufacturing of the mobile pump, virtually all requests can be considered. Whether hose holders, large storage boxes, working lights, tool boxes or holders for hose adapters, on your mobile unit there is a space for everything.

THE DRIVE AND THE TANK BASE FRAME [5]

Depending on the area of application and their design, our rotary lobe pumps are driven by an electric motor, a combustion motor or a PTO shaft of a vehicle. As an alternative, they can also be driven by means of a hydraulic motor. The drive can be equipped with a sound enclosure for use in residential areas.

When the unit is driven by a combustion motor, the fuel tank is integrated in the base frame of the pump with minimum space requirements. The unit comprising the pump, the motor and the base frame can easily be removed from the chassis and be transported to rough terrain by a crane or a helicopter.

BÖRGER CONTROL TECHNOLOGY [6]

The control technology is adapted to your individual requirements by Börger's electrical engineering department. All monitoring devices such as dry run protection, temperature monitoring, electronic seal monitoring or overpressure protection are controlled and monitored by the control technology which is easy to operate.

PUMP WITH THE HIGHEST FLOW RATE

THE MOBILE HIGH-PERFORMANCE PUMP



Our most powerful rotary lobe pumps with maximum flow rates of up to 24,000 l/min are installed on a truck trailer together with the drive.

The pumps can be very easily operated by means of the user-friendly control element. The required flow rate can be adjusted independently from the counter pressure. Various parameters of motor and pump activity are monitored and indicated on the multi-function display.

CONSTRUCTION

1 The rotary lobe pump

The high-performance pump and the pipe connectors are designed and manufactured individually to suit your application. The flow rate is variable.

2 The motor

A combustion motor (with sound enclosure upon request) drives the pump.

3 The control technology

User-friendly control of the pump via a clearly arranged control element with multi-function display.

4 The storage compartments

Various storage compartments are installed on the truck trailer.

5 MIP® (Maintenance in Place)

Even our largest pumps are very easy to maintain. In order to facilitate maintenance work on the pump, a wire rope hoist is attached at the roof. This way, even the large XL pumps can be maintained very easily.

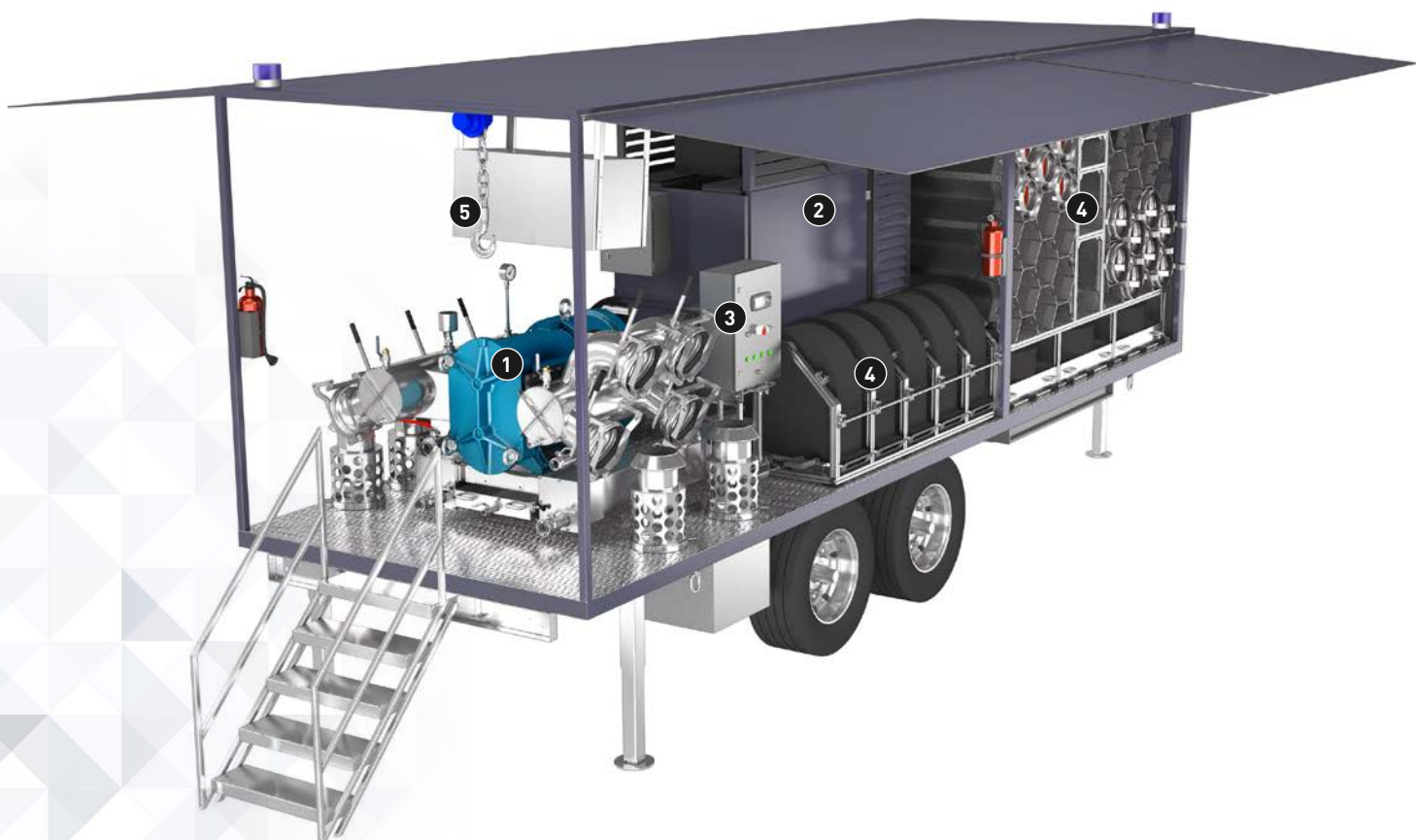

AT A GLANCE

- + Fully independent thanks to drive by means of a combustion motor
- + Flow rate of up to 24,000 l/min
- + Easy maintenance of the XL pumps thanks to on-board wire rope hoist
- + With additional power generator upon request
- + Sophisticated control technology
- + Motor with sound enclosure
- + Lots of space for storage compartments

FUNCTIONS AND OPTIONS

The mobile pumps on truck trailers are manufactured in our company in line with your individual wishes and requirements. From the pump size through a customized control technology right up to any special accessories – we make your wishes come true.

Operating element that can be lowered



Multi-function display



Various storage compartments

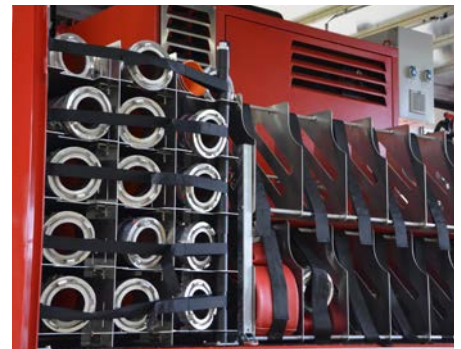

Retractable stairs



Illuminated interior



Motor with sound enclosure



FULLY INDEPENDENT ON A CAR TRAILER



Driven by a combustion motor, the Börger mobile pumps work fully independently. Börger rotary lobe pumps with a flow rate of up to 15,000 l/min. can be installed on a car trailer.

Whether a tarp / roof bow construction with a convertible roof or an additional power generator – nearly every request can be realized. The motor or the entire pump unit can be equipped with a sound enclosure for use in residential areas.

CONSTRUCTION

- 1 The rotary lobe pump**
The powerful rotary lobe pump and the pipe connectors are designed and manufactured individually to suit your application.
- 2 The motor**
The pumps installed on a car trailer are driven by a combustion motor in most cases. Upon request, the motor can be installed inside a sound enclosure.
- 3 The control technology**
The powerful rotary lobe pump is operated via the user-friendly Börger control unit.
- 4 The chassis**
A car trailer with single or tandem axle is selected depending on the requirements. Special axles are possible as well.



AT A GLANCE

- + Customized
- + Flow rate of up to 15,000 l/min
- + Fully independent thanks to drive by means of a combustion motor
- + A wide scope of special accessories can be made available upon request.
- + Sophisticated control technology
- + Also available with sound enclosure

ALTERNATIVE CONSTRUCTION

The Börger mobile pumps can also be installed on a skip container and/or as a cranable version on a base frame.

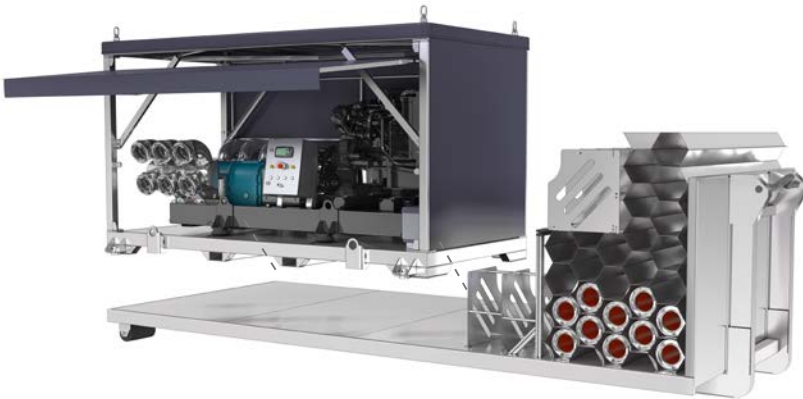

FUNCTIONS AND OPTIONS

The control unit is easy to operate



Weather protection roof can be set up



Various storage compartments



Swivelling hose connections



Automatic operation via level sensor



Drawbar that can be adjusted in height



SIMPLE AND EFFICIENT THE EMERGENCY PUMP



The emergency pump dispenses with an integrated drive. By means of the standardized three-point mounting, the pump (at the front or rear) can be attached to a Unimog or a tractor, lifted and transported to the installation site. The pump is driven by means of the PTO shaft of the vehicle at the operation site.

The emergency pump can be handled very easily. After the PTO shaft and hoses have been connected, the pump is immediately ready for use and conveys absolutely independently from the power supply.

The pump speed and flow rate can be simply and appropriately regulated via the speed of the PTO shaft. Pumps with flow rates of up to 15,000 l/min can be used for this mobile version.

CONSTRUCTION

1 The rotary lobe pump

The powerful rotary lobe pump is designed and manufactured individually to suit your application.

2 The standardized three-point mounting

The pump is installed on a base frame with standardized three-point mounting and can thus be transported by any tractor or Unimog.

3 The suction and pressure connections

The number of suction and pressure connections is freely selectable.

4 The forklift pockets

For longer transports, the compact pump can simply be loaded onto the cargo bed of a transporter or trailer by means of a forklift truck and the integrated forklift pockets.

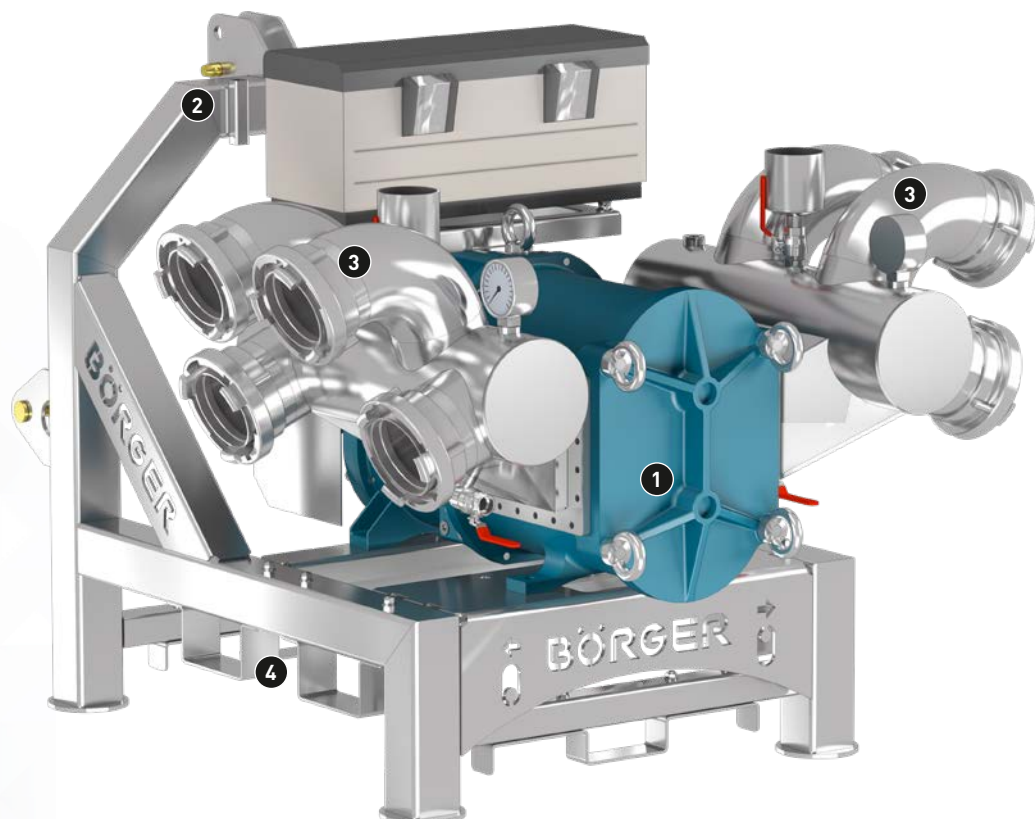

EMERGENCY PUMP AT A GLANCE

- + Customized
- + Ready for use right away
- + Can be used in every terrain
- + No integrated motor required
- + Compact and powerful
- + Very easy to operate

FUNCTIONS AND OPTIONS

Even on the very compact base frame of the emergency pump various accessories can be accommodated. The mobile PTO shaft pump can be driven, for example, by an optional control unit. Upon request, we also install an additional electric motor.

Standardized three-point mounting



With hose package



Pressure measurement



Type and number of suction and pressure connections can be selected



Drain for removal of residues



Tool box carried on the unit



EASY HANDLING

THE PORTABLE MOBILE PUMP



Börger has developed the portable mobile pump especially for use in areas which are difficult to access. This solids-resistant pump is designed such that the pump including the drive can be carried to the corresponding area of application.

The portable pump is built in such a compact way that the pump including the drive can be transported in the storage compartment of an emergency vehicle, on a truck bed or in a car trunk. Despite its small size, the pump covers flow rate ranges of up to 500 l/min.

The Börger hand cart pump is designed and manufactured individually to suit your application and thus can also be used, for example, as a hazardous material pump, extinguishing foam pump or skimmer pump. It can also be used in potentially explosive atmospheres.

CONSTRUCTION

1 The rotary lobe pump

The powerful rotary lobe pump is designed and manufactured individually to suit your application.

2 The motor

The pump is driven by an electric or a combustion motor. Upon request, the motor can be equipped with a frequency converter.

3 The handles

Using the hinged handles, the pump can be carried very easily and conveniently.

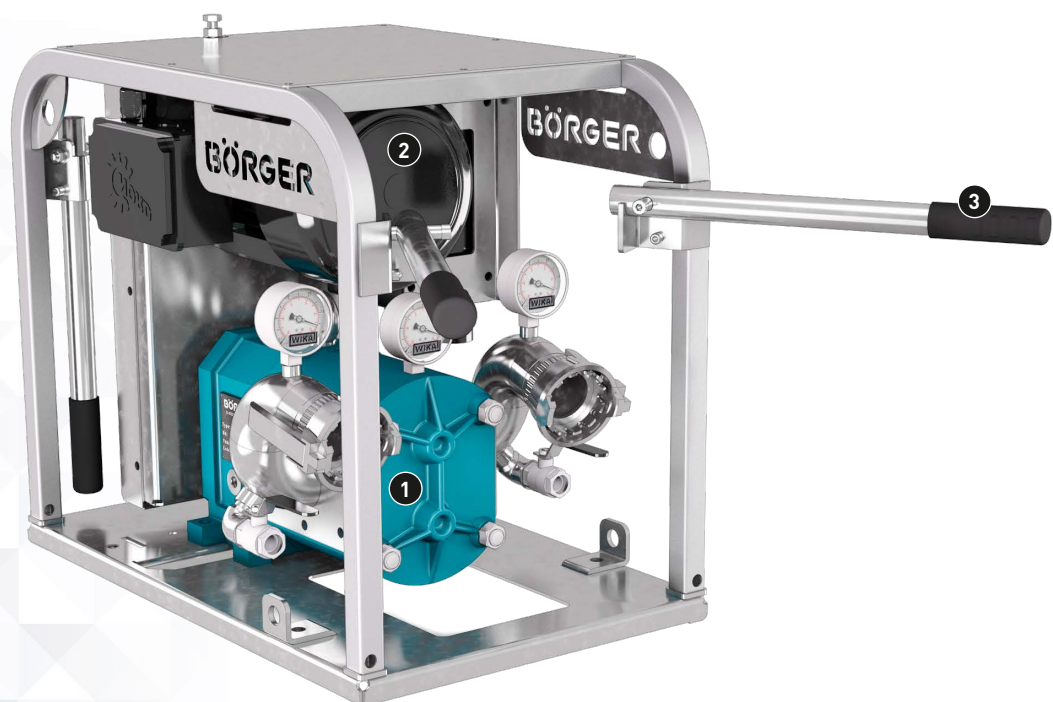

PORTABLE PUMP AT A GLANCE

+ Easy handling

+ Perfectly matched components

+ Chemically resistant

+ Upon request, in ATEX- or API 676-compliant design

+ Compact and powerful

+ Drive can be selected

VERSATILE USE

- Oil spill response pump
- Hazardous material pump
- Skimmer pump
- Extinguishing foam pump
- Disaster relief pump
- Conveying of aggressive or highly viscous liquids or media containing solids
- and so on

FUNCTIONS AND OPTIONS

With electric motor



With combustion motor



With a combustion motor, the pump can be carried by four persons



Very compact design



Versatile use



ATEX-compliant



BÖRGER®

EXCELLENCE – MADE TO LAST



Börgen GmbH
Borken-Weseke, Germany
Phone +49 2862 9103-0
info@boerger.de

Börgen Benelux
Ootmarsum, Netherlands
info@boerger.nl

Boerger LLC
Chanhassen, MN, USA
america@boerger.com

Börgen France Sarl
Wittersheim, France
info@borger.fr

Boerger Polska Sp. z o.o.
Gliwice, Poland
info@boerger.pl

Börgen UK Ltd.
Staffordshire, United Kingdom
uk@boerger.com

Boerger Pumps Asia Pte Ltd.
Singapore
asia@boerger.com

Boerger India Pvt Ltd.
Gurugram, Haryana, India
india@boerger.com

Boerger Pumps (Shanghai) Co., Ltd.
Pudong, Shanghai, China
shanghai@boerger.com

www.boerger.com